

A I B c I D I E I F I G I H I I J I K -----i 01 Issued

BREAK ALL EDGES UNLESS OTHERWISE STATE

9
8
7
6
5
4
3
2
1

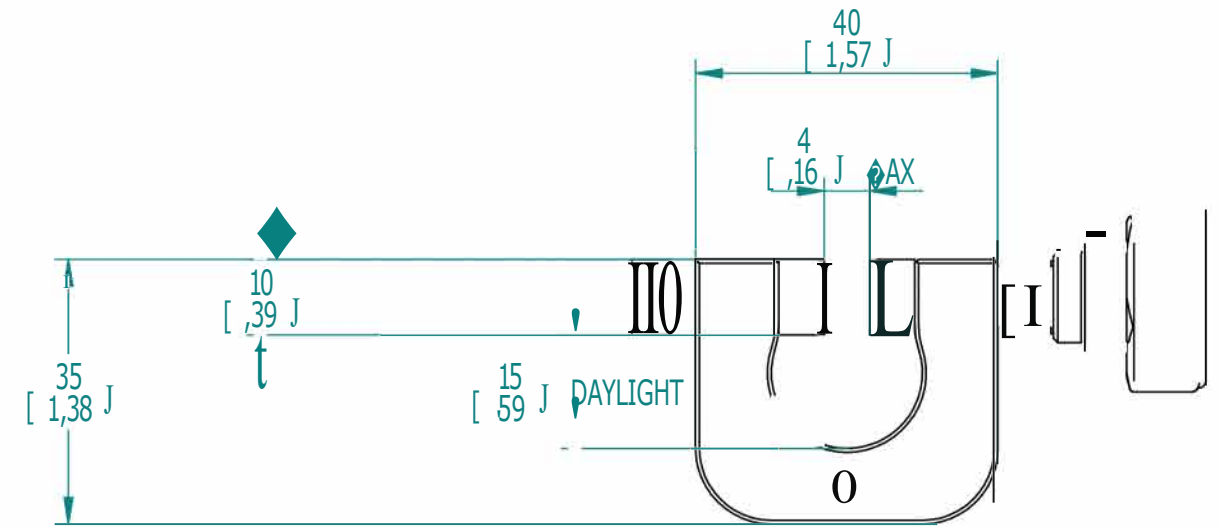
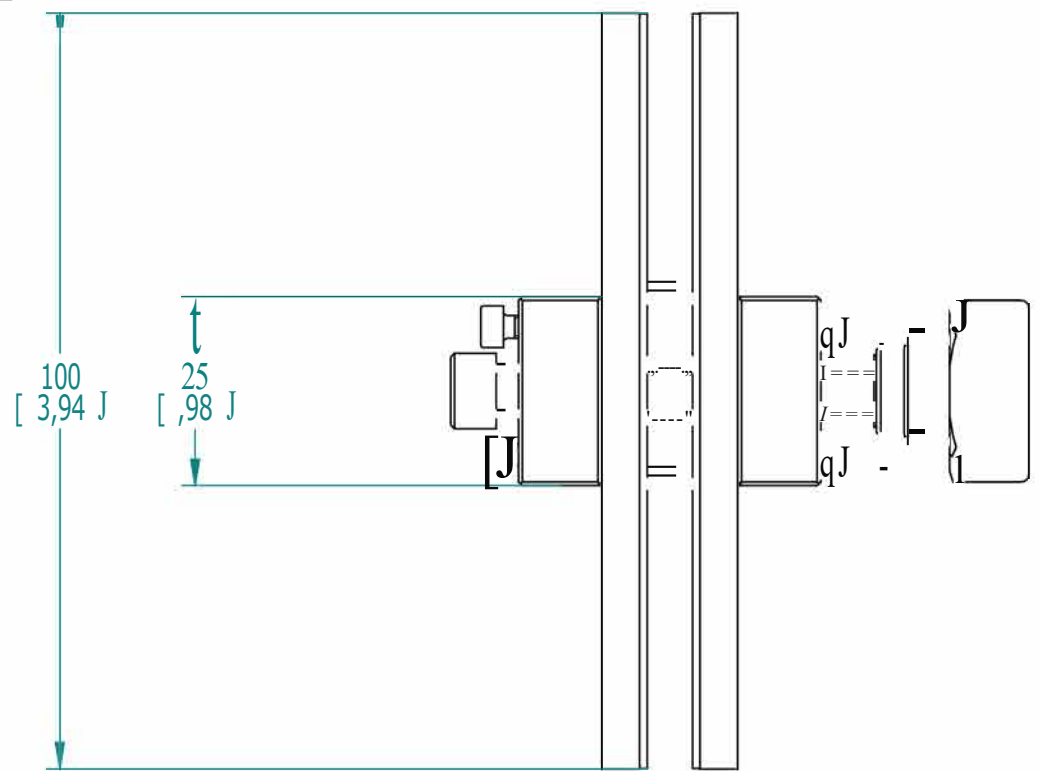

MATERIAL.

GENERAL TOLERANCES
DIMENSIONS TO :-
2 DECIMAL PLACES ± 0.10
1 DECIMAL PLACE ± 0.25
WHOLE FIGURES ± 0.50
ANGLES ± 1 DEG

CHAMFERS:-
45 DEG UNLESS STATED
THREADS:-
METRIC COARSE UNLESS STATED

SCALE. 2:1 @A3
© 2015
MAX CORNER RADIUS 0.25 UNLESS SPECIFIED
CONCENTRICITY TOLERANCE ± 0.10

DRAWN.
DATE.
CHECKED.
DATE.
DES AUTH.
DATE.

THIS DOCUMENT/ DRAWING IS ISSUED ON THE UNDERSTANDING THAT IT IS STRICTLY CONFIDENTIAL AND MAY NOT BE REPRODUCED OR UTILISED IN ANY WAY WITHOUT THE WRITTEN PERMISSION OF MECMESIN LTD.
TITLE.

FINISH.

TO BE READ IN CONJUNCTION WITH
B.S.8888.

SHEET NO.
1 OF 1

DRAWING No.
432-650